

model **INS118**

TOTAL CAPACITY	14,320 in ³	234 L
BASKET CAPACITY - UPPER	10,648 in ³	174 L
BASKET CAPACITY - LOWER	3,672 in ³	60 L
BASKET CAPACITY - REAR		
LOWER TRAY CAPACITY	3,978 in ³	65 L
LOWER TRAY CAPACITY - REAR		
NESTING DISTANCE	12.2"	311 mm
WEIGHT	56.6 lbs	25.7 kg
STANDARD FEATURES	Wheels: 2-5" Swivel, 2-5" Fixed Finish: E-Coat Weight: 25.7 kg [56.6 lbs] Payload: 175 kg [385 lbs]	

AVAILABLE FEATURES	Custom Colours	Cup/Floral Holder
	Custom Finishes	Bag Hook
	Cart Locks	Scanner Holder
	Anti-Static Wheel	Cart Containment Components (Factory Installed)
	Ergonomic Handle	
	Custom Leg hole covers	



5181 Everest Drive Mississauga, Ontario L4W 2R2
 1.888.473.3629 | www.instorecorp.com

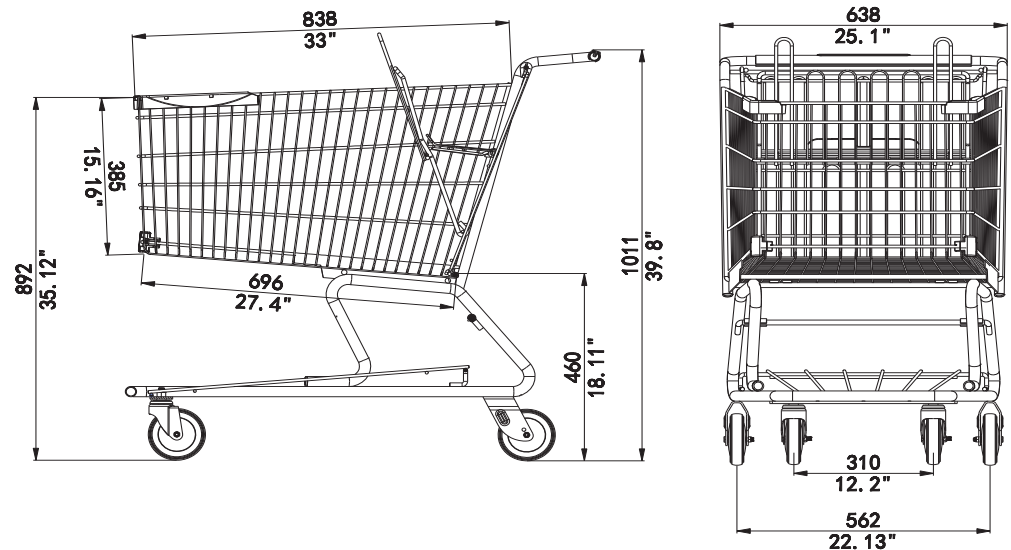

This slide and its contents are proprietary and strictly confidential. By its acceptance hereof, the recipient agrees not to copy, distribute or otherwise disclose to any third parties this slide or any of its contents without the prior written consent of In-Store Products Limited.

*Dimensions (inches/mm)