

model

MOVATOR
5BB7

| | | |
|----------------------------|--|---------|
| TOTAL CAPACITY | 13,770 in ³ | 225 L |
| BASKET CAPACITY - UPPER | 3,366 in ³ | 55 L |
| BASKET CAPACITY - LOWER | 4,896 in ³ | 80 L |
| BASKET CAPACITY - REAR | | |
| LOWER TRAY CAPACITY | 5,508 in ³ | 90 L |
| LOWER TRAY CAPACITY - REAR | | |
| NESTING DISTANCE | 11.42" | 290 mm |
| WEIGHT | 75.2 lbs | 34.2 kg |
| STANDARD FEATURES | E-Coat + Powder Coat 1" round handle Bumpers 5" Polyurethane wheels ASTM approved Nylon Seatbelt | |

| | | |
|--------------------|------------------------|---|
| AVAILABLE FEATURES | Custom Colours | Cup/Floral Holder |
| | Custom Finishes | Bag Hook |
| | Cart Locks | Scanner Holder |
| | Anti-Static Wheel | Cart Containment Components (Factory Installed) |
| | Ergonomic Handle | |
| | Custom Leg hole covers | |



5181 Everest Drive Mississauga, Ontario L4W 2R2
1.888.473.3629 | www.instorecorp.com

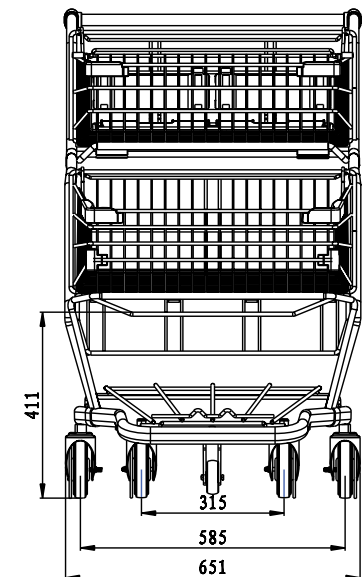
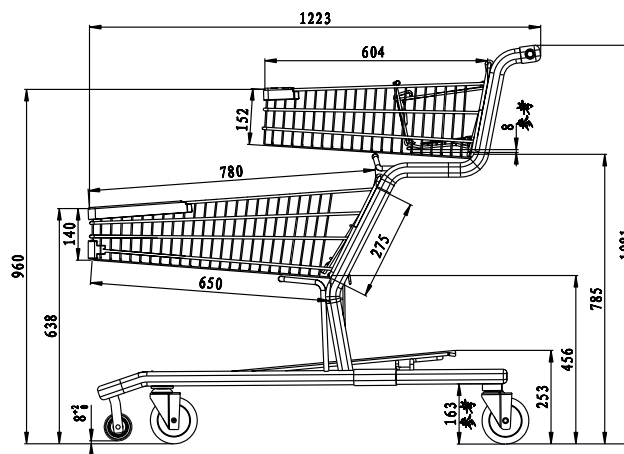

*Dimensions (mm)