

model

PFLOW  
**2BB2**

|                            |  |        |
|----------------------------|--|--------|
| TOTAL CAPACITY             | 5,121 in <sup>3</sup>  | 84 L   |
| BASKET CAPACITY - UPPER    | 2,019 in <sup>3</sup>  | 33 L   |
| BASKET CAPACITY - LOWER    | 2,368 in <sup>3</sup>  | 39 L   |
| BASKET CAPACITY - REAR     | 734 in <sup>3</sup>  | 12 L   |
| LOWER TRAY CAPACITY        |  |        |
| LOWER TRAY CAPACITY - REAR |  |        |
| NESTING DISTANCE           | 11.22"   | 285 mm |
| WEIGHT                     | 48.4 lbs   | 22 kg  |
| STANDARD FEATURES          | E-Coat + Powder Coat<br>1" round handle<br>Bumpers<br>5" Polyurethane wheels<br>Pflow Towbar |        |

|                    |                   |   |
|--------------------|-------------------|---|
| AVAILABLE FEATURES | Custom Colours    | Cup/Floral Holder                               |
|                    | Custom Finishes   | Bag Hook  |
|                    | Cart Locks        | Scanner Holder                                  |
|                    | Anti-Static Wheel | Cart Containment Components (Factory Installed) |
|                    | Ergonomic Handle  |   |



5181 Everest Drive Mississauga, Ontario L4W 2R2  
1.888.473.3629 | www.instorecorp.com

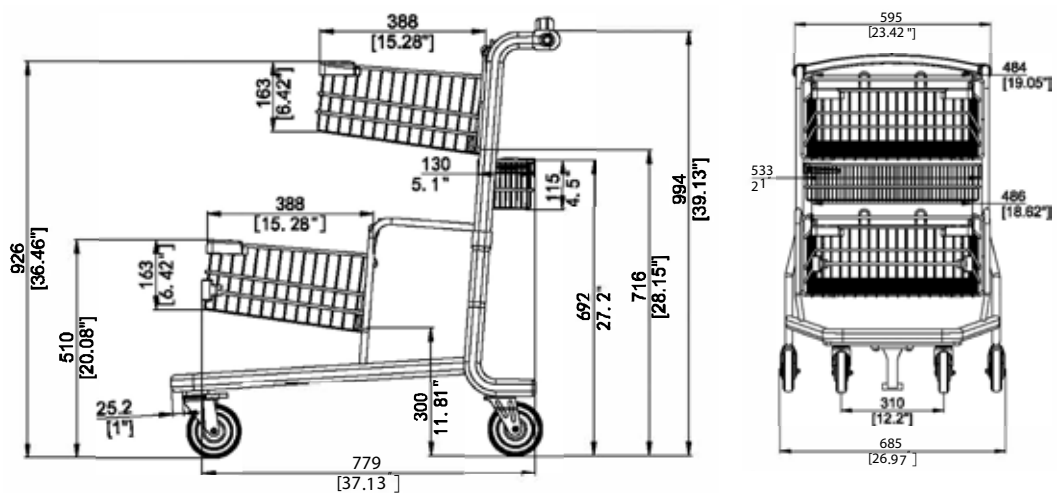

\*Dimensions (mm). Specifications reflect Up and Down model only. Please inquire for Up only or Down only specifications if interested.